

HEADER ONE

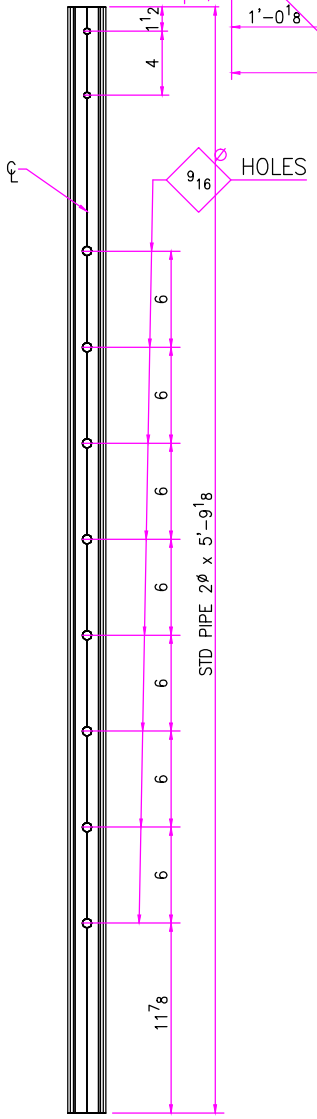
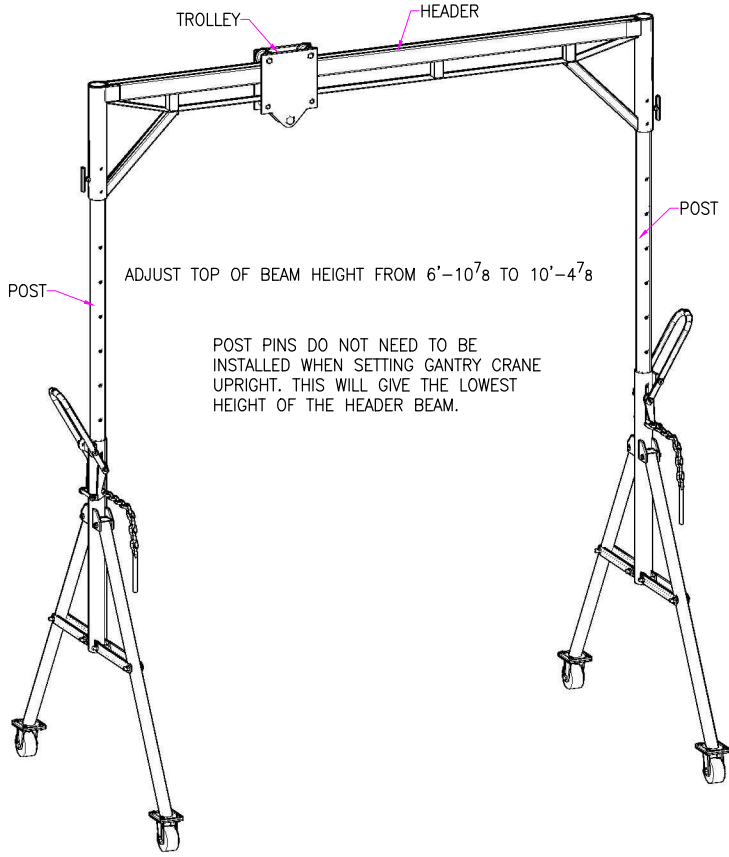

QUANTITY	SHIPPING MARK	DESCRIPTION	FEET	INCHES	ASSEMBLY MARK	REMARKS	TOTAL WEIGHT
ONE		HEADER					
2		HSS 2.875 x .188	1	7 1/2	ma		17.6
2		HSS 1 1/2 x 1 1/2 x 1/8	1	6 11/16	mb		6.9
4		HSS 1 1/2 x 1 1/2 x 1/8	0	2 7/8	mc		2.1
ONE		HSS 3x2x 1/8	8	0	md		31.2
2		R 1/8x2 7/8	0	2 7/8	pa		0.6
ONE		FB 1/8x2	8	7	pb		7.3
2		R 1/8x3 1/4	0	1 1/2	pc		0.1
4		R 1/8x2 1/2	0	2 1/2	pd		0.9
4		BOLT 3/8 W/NUT	0	4			
2		BOLT 3/8 W/NUT	0	1			
2		FB 1/4x1/2	0	4	bd		0.3
2	POST	STD PIPE 2"	5	9 1/8			41.1
TOTAL WEIGHT:							108.1

ASD AutoSD Steel Detailing  
Meridian, Mississippi

PROJECT 1 1/2 TON GANTRY CRANE  
LOCATION MERIDIAN, MS  
DETAIL OF HEADER & POST USING 2" PIPE

REVISIONS

Holes 13 3/20	PAINT	DRAWN CRH	CHECKED	SHEET # ONE	JOB #
---------------	-------	-----------	---------	-------------	-------

UNLESS NOTED

POST  
2





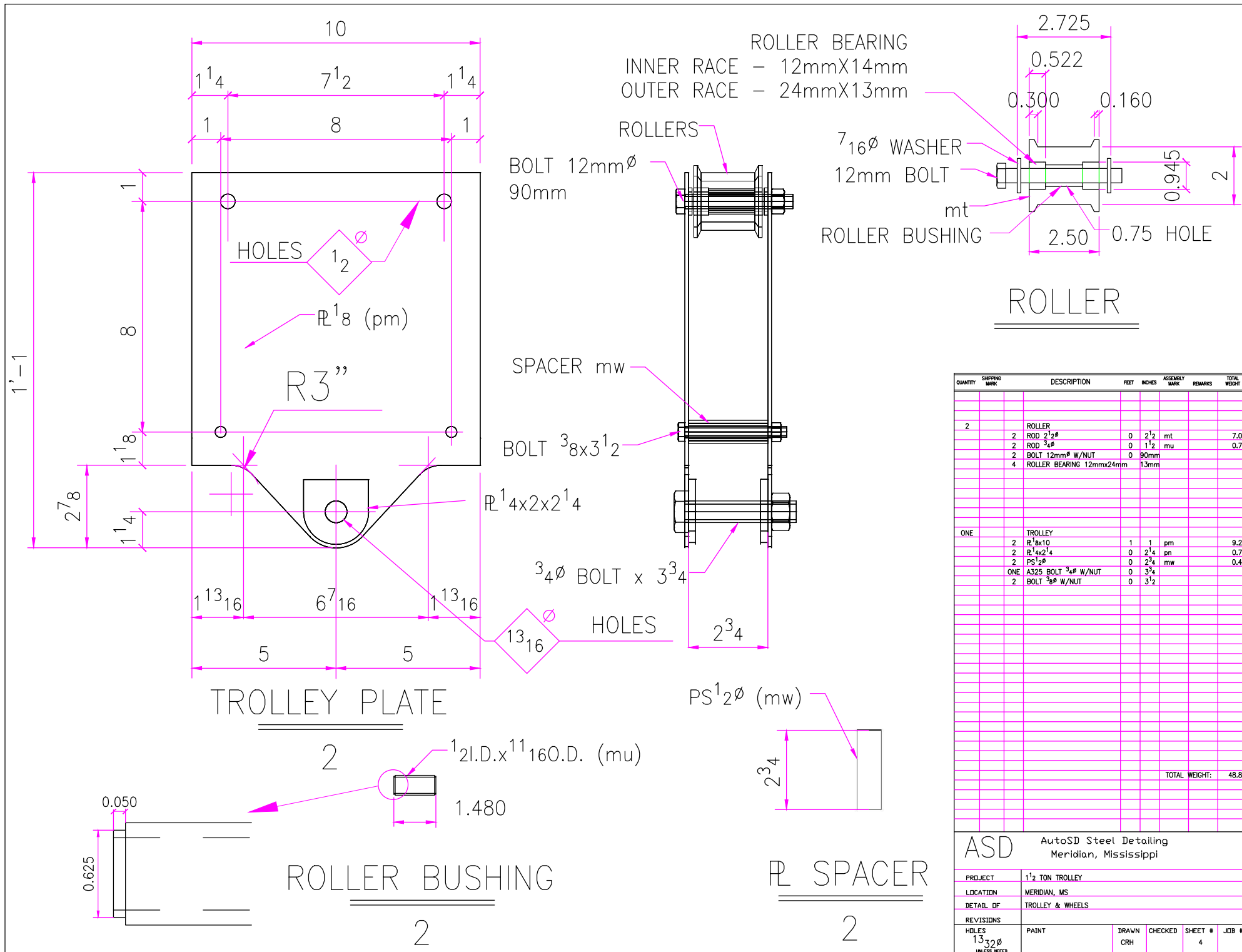

QUANTITY	SHIPPING MARK	DESCRIPTION	FEET	INCHES	ASSEMBLY MARK	REMARKS	TOTAL WEIGHT
2		ROLLER					
2		ROD 2 1/2 $\emptyset$	0	2 1/2	mt		7.0
2		ROD 3/4 $\emptyset$	0	1 1/2	mu		0.7
2		BOLT 12mm $\emptyset$ W/NUT	0	90mm			
4		ROLLER BEARING 12mmx24mm		13mm			
ONE		TROLLEY					
2		R 1/8 x 10	1	1	pm		9.2
2		R 1/4 x 2 1/4	0	2 1/4	pn		0.7
2		PS 1/2 $\emptyset$	0	2 3/4	mw		0.4
ONE		A325 BOLT 3/4 $\emptyset$ W/NUT	0	3 3/4			
2		BOLT 3/8 $\emptyset$ W/NUT	0	3 1/2			
TOTAL WEIGHT:							48.8

ASD AutoSD Steel Detailing  
Meridian, Mississippi

PROJECT	1 1/2 TON TROLLEY				
LOCATION	MERIDIAN, MS				
DETAIL OF	TROLLEY & WHEELS				
REVISIONS					
HOLES	PAINT	DRAWN	CHECKED	SHEET #	JOB #
13 3/2 $\emptyset$		CRH		4	
UNLESS NOTED					